

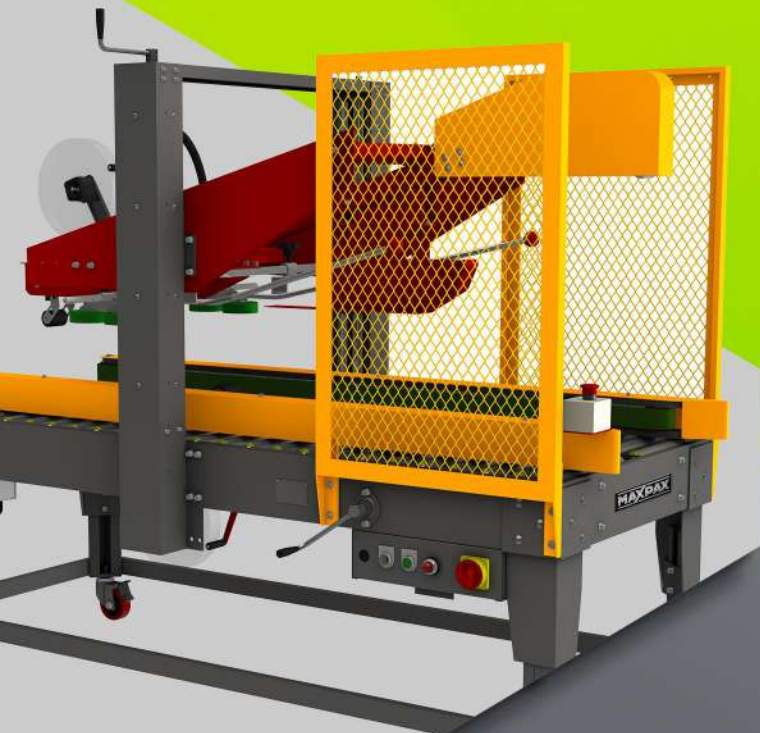

CATALOGUE

TAIWAN CARTON SEALER



JAKARTA

Jalan Gunung Sahari XI No. 76A

021 623 20 700

jakarta@wiratech.co.id

SURABAYA

Jalan Bubutan 79

031 545 88 53

surabaya@wiratech.co.id

WIRATECH.CO.ID

Packway Tape Heads

Packway patent tape heads featured with adjustable tension spring for four levels according to user's preference. Moreover, the one-way bearing allows smooth sealing finish

C-3



- 1.5" or 2" use with 30 mm overlap
- For PW-562M only.

C-1



- 2" or 3" use with 60±5 or 40±5 mm overlap
- 70±5 and 90±5 mm available up on request.

C-6



- 2" or 3" use with 60±5 mm overlap
- For PW-542S only.

Carton Erecting Reference Table

Model	Sealing Range (mm)				Loading Weight (Kgs)	Working Table Height (mm)
	OPP	L	W	H		
PW-563BE	n/a	250 ~ 500	200 ~ 500	150 ~ 500	20	600 ~ 900
PW-563P	n/a	250 ~ 500	200 ~ 400	100 ~ 500	20	671~871
PW-568ERT-ML	2"	250 ~ 510	200 ~ 380	120 ~ 500	n/a	615
	3"					

Sealing Range Reference Table

Model	Sealing Range (mm)				Loading Weight (Kgs)	Working Table Height (mm)
	OPP	L	W	H		
PW-551TB	2"	150 ~ ∞	200 ~ 500	120 ~ 500	30	570 ~ 810
	3"	150 ~ ∞	225 ~ 500	120 ~ 500		
PW-552TB	2"	150 ~ ∞	200 ~ 500	120 ~ 500	30	720 ~ 810
	3"	150 ~ ∞	225 ~ 500	120 ~ 500		
PW-553S	2"	150 ~ ∞	120 ~ 500	85 ~ 500	30	550 ~ 810
	3"	150 ~ ∞	145 ~ 500	85 ~ 500		
PW-554TS	2"	150 ~ ∞	200 ~ 500	120 ~ 500	50	550 ~ 810
	3"	150 ~ ∞	225 ~ 500	120 ~ 500		
PW-542S	2"	150 ~ ∞	120 ~ 500	110 ~ 500	30	560 ~ 760
PW-570	2"	150 ~ ∞	200 ~ 600	130 ~ 400	30	600 ~ 810
	3"	150 ~ ∞	225 ~ 600	130 ~ 400		
PW-562M	1.5"	120 ~ ∞	80 ~ 200	50 ~ 300	20	670 ~ 810
	2"	120 ~ ∞	100 ~ 200	50 ~ 300	20	670 ~ 810
PW-553SF	2"	250 ~ 500	250 ~ 500	85 ~ 500	30	550 ~ 810
	3"					
PW-553SFTB	2"	250 ~ 500	250 ~ 500	150 ~ 500	30	550 ~ 810
	3"					
PW-557F	2"	200 ~ 600	120 ~ 500	110 ~ 500	30	550 ~ 810
	3"	200 ~ 600	145 ~ 500	110 ~ 500		
PW-558F	2"	200 ~ 550	200 ~ 500	120 ~ 500	50	550 ~ 810
	3"	200 ~ 550	225 ~ 500	120 ~ 500		
PW-555AU	2"	300 ~ ∞	120 ~ 500	150 ~ 500	30	550 ~ 810
	3"	300 ~ ∞	145 ~ 500	150 ~ 500		
PW-555AUC	2"	300 ~ ∞	120 ~ 500	150 ~ 500	30	550 ~ 810
	3"	300 ~ ∞	145 ~ 500	150 ~ 500		
PW-556AU	2"	300 ~ ∞	200 ~ 500	150 ~ 500	50	550 ~ 810
	3"	300 ~ ∞	225 ~ 500	150 ~ 500		
PW-559AF	2"	300 ~ 500	200 ~ 500	160 ~ 500	30	550 ~ 810
	3"					
PW-569SAF	2"	300 ~ 500	200~400	160 ~ 500	30	650 ~ 820
	3"					
PW-566EG	3"	300 ~ 600	250 ~ 500	140 ~ 500	30	630 ~ 870
PW-566AEG	3"	300 ~ 700	250 ~ 500	150 ~ 500	40	670 ~ 830
PW-553SB (Manual Sizing)	2"	300 ~ 700	120 ~ 500	110 ~ 500	30	550 ~ 810
	3"	300 ~ 700	145 ~ 500	110 ~ 500		
PW-555AB (Random Sizing)	2"	300 ~ 700	120 ~ 500	150 ~ 500	30	550 ~ 810
	3"	300 ~ 700	145 ~ 500	150 ~ 500		

*Specifications subject to change without notice.

Carton Erectors



PW-563BE

PW-563BE Box Folding Pack Station

BE: Basic and Economic

Power	Pneumatic drive, requirement 6kgf/cm ² (137.64L/min.)
Folding Size	L250~500 x W200~500 x H150~500 mm
Capacity	Depends on carton positioning speed
Machine Size	L1004 x W700 x H600~900 mm

Options

- In Stainless Steel Structure #304

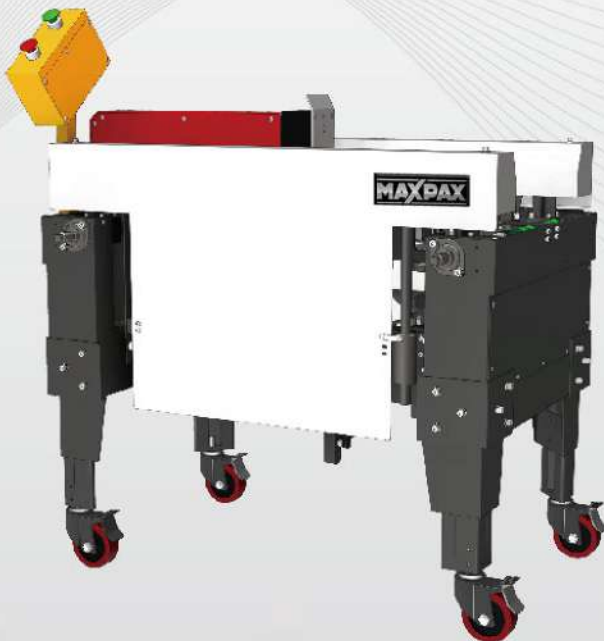

PW-563P

PW-563P Box Folding Pack Station

P: With Push Carton Device

Power	Pneumatic drive, requirement 6kgf/cm ² (137.64L/min.)
Folding Size	L250~500 x W200~400 x H100~500 mm
Capacity	Depends on carton positioning speed
Machine Size	L1117 x W862 x H1106~1306 mm

Options

- In Stainless Steel Structure #304

PW-568ERT-ML Automatic Carton Erector

ERT: Carton Erectors - Vertical Style

ML: Medium Size for Left Side Exit

Tape Width	2" or 3"
Belt Speed	20M/min.(50Hz)
Sealing Size	L250~510 x W200~380 x H120~500 mm (for 2" and 3")
Air Supply	6kgf/cm ² (137.64L/min.)
Power Supply	3Ø, 220/380/415/440V (50/60Hz)
Machine Size	L 2502 x W 2359 x H 1547 mm

Options

- In Stainless Steel Structure #304
- Right side or Left side operation.



Features

- HMI Touch Panel Control System
- Equipped with detection for no tape, tape sealing failure and tape cutting failure

PW-568ERT-ML

Manual Adjustment Models



PW-551TB

PW-551TB Carton Sealer For Uniform Size Cartons

TB: Top and Bottom Belt Drive

Tape Width	2" or 3"
Belt Speed	20M/min. (approx. 30 cartons/min.)
Sealing Size	(2") L150~∞ x W200~500 x H120~500 mm (3") W +25 mm
Power Supply	1Ø, 110/220/230/240V (50/60Hz); 3Ø made on request
Machine Size	L 1200 x W 779 x H 1420~1765 mm
Operation	Table with small rollers, side guide rails adjust separately

Options

- 60 Sec. auto Stop
- Extension Roller Tables
- In Stainless Steel Structure #304
- P.C.B. control



PW-552TB

PW-552TB Carton Sealer For Uniform Size Cartons

TB: Top and Bottom Belt Drive

Tape Width	2" or 3"
Belt Speed	20M/min. (approx. 30 cartons/min.)
Sealing Size	(2") L150~∞ x W200~500 x H120~500 mm (3") W +25 mm
Power Supply	1Ø, 110/220/230/240V (50/60Hz); 3Ø made on request
Machine Size	L 1044 x W 779 x H 1569~1764 mm
Operation	Table with full belt cover, side guide rails adjust simultaneously

Options

- 60 Sec. auto Stop
- Extension Roller Tables
- In Stainless Steel Structure #304
- P.C.B. control



PW-553S

PW-553S Carton Sealer For Uniform Size Cartons

S: Side Belt Drive

Tape Width	2" or 3"
Belt Speed	20M/min. (approx. 30 cartons/min.)
Sealing Size	(2") L150~∞ x W120~500 x H85~500 mm (3") W +25 mm
Power Supply	1Ø, 110/220/230/240V (50/60Hz); 3Ø made on request
Machine Size	L 1280 x W 964 x H 1396~1761 mm

Options

- 60 Sec. auto Stop
- Extension Roller Tables
- In Stainless Steel Structure #304
- P.C.B. control



PW-553SC

PW-553SC Carton Sealer For Uniform Size Cartons

S : Side belt drive ; C : Competitive

Tape Width	2" or 3"
Belt Speed	20M/min. (approx. 30 cartons/min.)
Sealing Size	L150~∞ x W145~500 x H120~500 mm (for 2" and 3")
Power Supply	1Ø, 110/220/230/240V (50/60Hz);
Machine Size	L 830 x W 885 x H 1389~1589 mm

Options

- Extension roller L470 x W360mm



PW-554TS

PW-554TS Carton Sealer For Uniform Size Cartons

TS: Top and Side Belt Drive

Tape Width	2" or 3"
Belt Speed	20M/min. (approx. 30 cartons/min.)
Sealing Size	(2") L150~∞ x W200~500 x H120~500 mm (3") W +25 mm
Power Supply	1Ø, 110/220/230/240V (50/60Hz); 3Ø made on request
Machine Size	L 1280 x W 964 x H 1396~1761 mm

Options

- 60 Sec. auto Stop
- Extension Roller Tables
- In Stainless Steel Structure #304
- P.C.B. control

Manual Adjustment Models



PW-542S

PW-542S Carton Sealer For Uniform Size Cartons

S: Side Belt Drive

Tape Width	2" or 3"
Belt Speed	20M/min. (approx. 30 cartons/min.)
Sealing Size	(2") L 150 ~ ∞ x W 120 ~ 500 x H 110 ~ 500 mm (3") W + 25 mm
Power Supply	1Ø, 110/220/230/240V (50/60Hz); 3Ø made on request
Machine Size	L 960 x W 943 x H 1363 ~ 1563 mm
Operation	Easy tape threading design

Options

- 60 Sec. auto Stop
- Extension Roller Tables
- In Stainless Steel Structure #304



PW-562M

PW-562M Carton Sealer For Uniform Size Cartons

M: Mini Type with Side Belt Drive

Tape Width	1.5" or 2"
Belt Speed	18M/min. (approx. 25 cartons/min.)
Sealing Size	(1.5") L 120 ~ ∞ x W 80 ~ 200 x H 50 ~ 300 mm (2") W + 20 mm
Power Supply	1Ø, 110/220/230/240V (50/60Hz)
Machine Size	L 1090 x W 659 x H 1210 ~ 1350 mm

Options

- 60 Sec. auto Stop
- In Stainless Steel Structure #304

PW-570 Carton Sealer For Uniform Size Cartons

Side Seal with Top and Bottom Belt Drive

Tape Width	2" or 3"
Belt Speed	20M/min. (approx. 30 cartons/min.)
Sealing Size	(2") L150~∞ x W200~600 x H130~400 mm (3") H +25 mm
Power Supply	1Ø, 110/220/230/240V (50/60Hz); 3Ø made on request
Machine Size	L 915 x W 1069 x H 1341 ~ 1551 mm

Options

- 60 Sec. auto Stop
- In Stainless Steel Structure #304
- Use for random size cartons (PW-570A)

Features

- Suitable for Styrofoam box
- Top mast with cushion for smooth sealing
- Top & bottom belt driven with special bearing: Precise, Low noise, Durable parts and belt

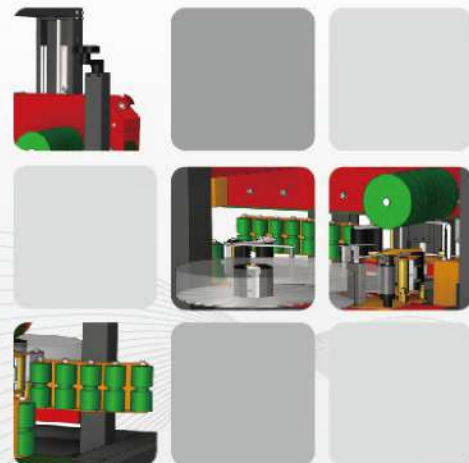

PW-570

Manual Adjustment With Side Folding Models



PW-553SF

PW-553SF Carton Sealer For Uniform Size Cartons

SF: Side Belt Drive with Top Flap Folding

Tape Width	2" or 3"
Belt Speed	20M/min. (approx. 15 cartons/min.)
Sealing Size	L250~500 x W250~500 x H85~500 mm (for 2"and 3")
Power Supply	1Ø, 110/220/230/240V (50/60Hz); 3Ø made on request
Machine Size	L 1280 x W 964 x H 1396 ~ 1761 mm

Options

- 60 Sec. auto Stop
- Extension Roller Tables
- In Stainless Steel Structure #304



PW-553SFTB

PW-553SFTB Carton Sealer For Uniform Size Cartons

SFTB: Side Belt Drive with Top and Bottom Flap Folding

Tape Width	2" or 3"
Belt Speed	20M/min. (approx. 15 cartons/min.)
Sealing Size	L250~500 x W250~500 x H150~500 mm (for 2"and 3")
Power Supply	1Ø, 110/220/230/240V (50/60Hz); 3Ø made on request
Machine Size	L 2840 x W 964 x H 1396 ~ 1761 mm

Options

- 60 Sec. auto Stop
- Extension Roller Tables
- In Stainless Steel Structure #304

PW-557F Carton Sealer For Uniform Size Cartons

F: Automatic Top Flap Folding With Side Belt Drive

Tape Width	2" or 3"
Belt Speed	20M/min. (approx. 11 cartons/min.)
Sealing Size	(2") L200~600 x W120~500 x H110~500 mm ,(3") W +25mm
Air Supply	6kgf/cm ² (137.64L/min.)
Power Supply	1Ø, 110/220/230/240V (50/60Hz); 3Ø made on request
Machine Size	L 2086 x W 1002 x H 1551~1916 mm
Operation	With 60 sec. automatic stop function

Options

- Extension Roller Tables
- In Stainless Steel Structure #304
- Detection for no tape, tape sealing failure and tape cutting failure.



PW-557F



PW-558F

PW-558F Carton Sealer For Uniform Size Cartons

F: Automatic Top Flap Folding With Top and Side Belt Drive

Tape Width	2" or 3"
Belt Speed	20M/min. (approx. 11 cartons/min.)
Sealing Size	(2") L200~550 x W200~500 x H120~500 mm ,(3") W +25mm
Air Supply	6kgf/cm ² (137.64L/min.)
Power Supply	1Ø, 110/220/230/240V (50/60Hz); 3Ø made on request
Machine Size	L 2086 x W 1002 x H 1551 ~ 1916 mm
Operation	With 60 sec. Automatic Stop Function Best Suitable for Heavy or Tall/Thin Cartons

Options

- Extension Roller Tables
- In Stainless Steel Structure #304
- Detection for no tape, tape sealing failure and tape cutting failure.

Automatic Adjustment Models



PW-555AU

PW-555AU Carton Sealer For Random Size Cartons

AU: Automatic Height Search from Top
With Side Belt Drive

Tape Width	2" or 3"
Belt Speed	20M/min. (approx. 8 cartons/min.)
Sealing Size	(2") L 300 ~ ∞ x W 120 ~ 500 x H 150 ~ 500 mm (3") W +25mm
Air Supply	6kgf/cm ² (137.64L/min.)
Power Supply	1Ø, 110/220/230/240V (50/60Hz); 3Ø made on request
Machine Size	L 1319 x W 930 x H 1316 ~ 1576 mm
Operation	In Random or Height Memory Function (Adjustable)

Options

- Extension Roller Tables
- In Stainless Steel Structure #304



PW-555AUC

PW-555AUC Carton Sealer For Random Size Cartons

AUC: Automatic Height Search from Top with Side Compression Rollers
With Side Belt Drive

Tape Width	2" or 3"
Belt Speed	20M/min. (approx. 8 cartons/min.)
Sealing Size	(2") L300 ~ ∞ x W 120 ~ 500 x H 150 ~ 500 mm (3") W +25mm
Air Supply	6kgf/cm ² (137.64L/min.)
Power Supply	1Ø, 110/220/230/240V (50/60Hz); 3Ø made on request
Machine Size	L 1079 x W 933 x H 1316~1576 mm
Operation	In Random or Height Memory Function (Adjustable)

Options

- Extension Roller Tables
- In Stainless Steel Structure #304



PW-556AU

PW-556AU Carton Sealer For Random Size Cartons

AU: Automatic Height Search from Top
With Top and Side Belt Drive

Tape Width	2" or 3"
Belt Speed	20M/min. (approx. 8 cartons/min.)
Sealing Size	(2") L 300 ~ ∞ x W 200 ~ 500 x H 150 ~ 500 mm (3") W +25mm
Air Supply	6kgf/cm ² (137.64L/min.)
Power Supply	1Ø, 110/220/230/240V (50/60Hz); 3Ø made on request
Machine Size	L 1319 x W 933 x H 1316~1576 mm
Operation	In Random or Height Memory Function (Adjustable)

Options

- Extension Roller Tables
- In Stainless Steel Structure #304

PW-559AF Fully Automatic Carton Sealer For Random Size Cartons

AF: Fully Automatic Top Flap Folding With Side Belt Drive

Tape Width	2" or 3"
Belt Speed	20M/min. (approx. 5 cartons/min.)
Sealing Size	L300~500 x W200~500 x H160~500 mm (for 2" and 3")
Air Supply	6kgf/cm ² (137.64L/min.)
Power Supply	3Ø, 220/380/415/440V (50/60Hz)
Machine Size	L 2120 x W 1176 x H 1672~1932 mm

Options

- Extension Roller Tables
- In Stainless Steel Structure #304
- Detection for no tape, sealing failure, tape cutting failure

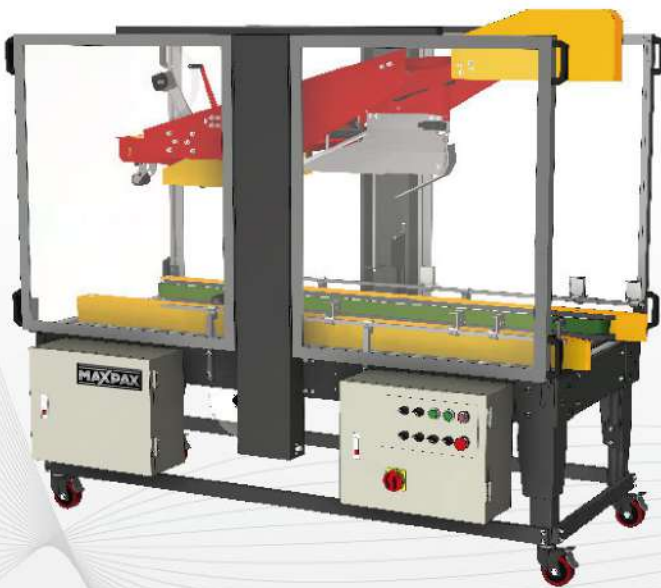

PW-559AF

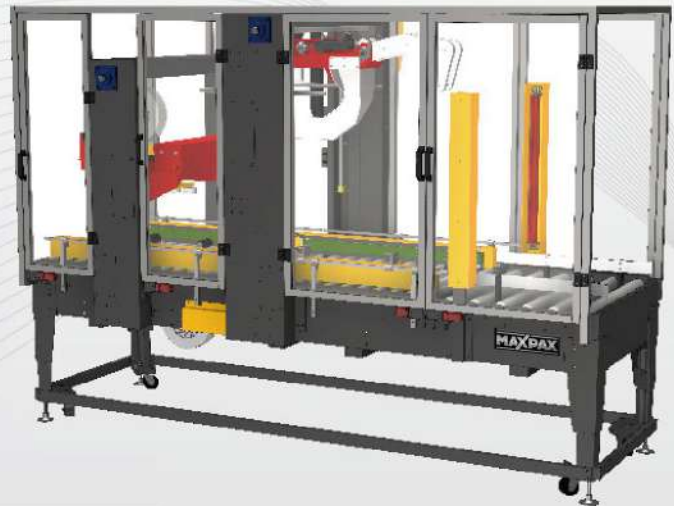

PW-569SAF

PW-569SAF Fully Automatic Carton Sealer For Random Size Cartons

SAF: Fully Automatic Top Flap Folding with Servo System for Positioning With Side Belt Drive

Tape Width	2" or 3"
Belt Speed	33M/min. (approx. 16 cartons/min.)
Sealing Size	L300~500 x W200~400 x H160~500 mm (for 2" and 3")
Air Supply	6kgf/cm ² (137.64L/min.)
Power Supply	3Ø, 220/380/415/440V (50/60Hz)
Machine Size	L 2859 x W 1306 x H 2021 mm

Operation

- HMI Touch Panel Control System
- Equipped with detection for no tape, tape sealing failure and tape cutting failure (suitable for system operation)

Edge Sealers



PW-566EG

PW-566EG Carton Edge Sealer for Uniform Size Cartons

EG: Edge Sealing with Top and Bottom Belt Drive

Tape Width	3"
Belt Speed	20M/min. (approx. 5 cartons/min.)
Sealing Size	L 300 ~ 600 x W 250 ~ 500 x H 140 ~ 500 mm
Air Supply	6kgf/cm ² (137.64L/min.)
Power Supply	3Ø, 220/380/415/440V (50/60Hz)
Machine Size	L 1500 x W 1471 x H 1593~1722 mm
Operation	Height Adjustment by Motor Driven Controls

Options

- Extension Roller Tables
- In Stainless Steel Structure #304
- Detection for no tape, sealing failure, tape cutting failure

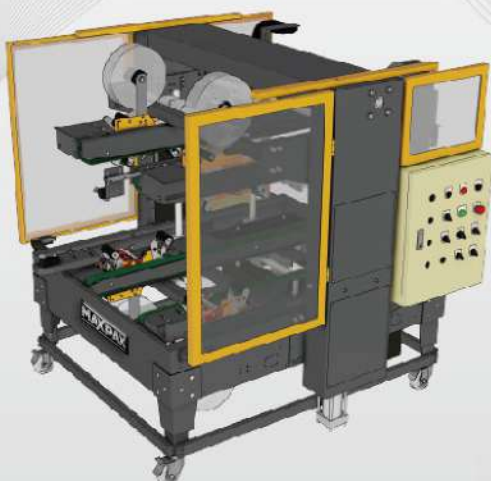

PW-566AEG

PW-566AEG Carton Edge Sealer for Random Size Cartons

AEG: Automatic Edge Sealing with Top and Bottom Belt Drive

Tape Width	3"
Belt Speed	20M/min. (approx. 4 cartons/min.)
Sealing Size	L 300 ~ 700 x W 250 ~ 500 x H 150 ~ 500 mm
Air Supply	6kgf/cm ² (137.64L/min.)
Power Supply	3Ø, 220/380/415/440V (50/60Hz)
Machine Size	L 1639 x W 1630 x H 1658~1818 mm

Options

- Extension Roller Tables
- In Stainless Steel Structure #304
- Detection for no tape, sealing failure, tape cutting failure



JAKARTA

Jalan Gunung Sahari XI No. 76A

021 623 20 700

jakarta@wiratech.co.id

SURABAYA

Jalan Bubutan 79

031 545 88 53

surabaya@wiratech.co.id

WIRATECH.CO.ID